

**Glasgow School of Art Course Specification
Audio Visual Technology**

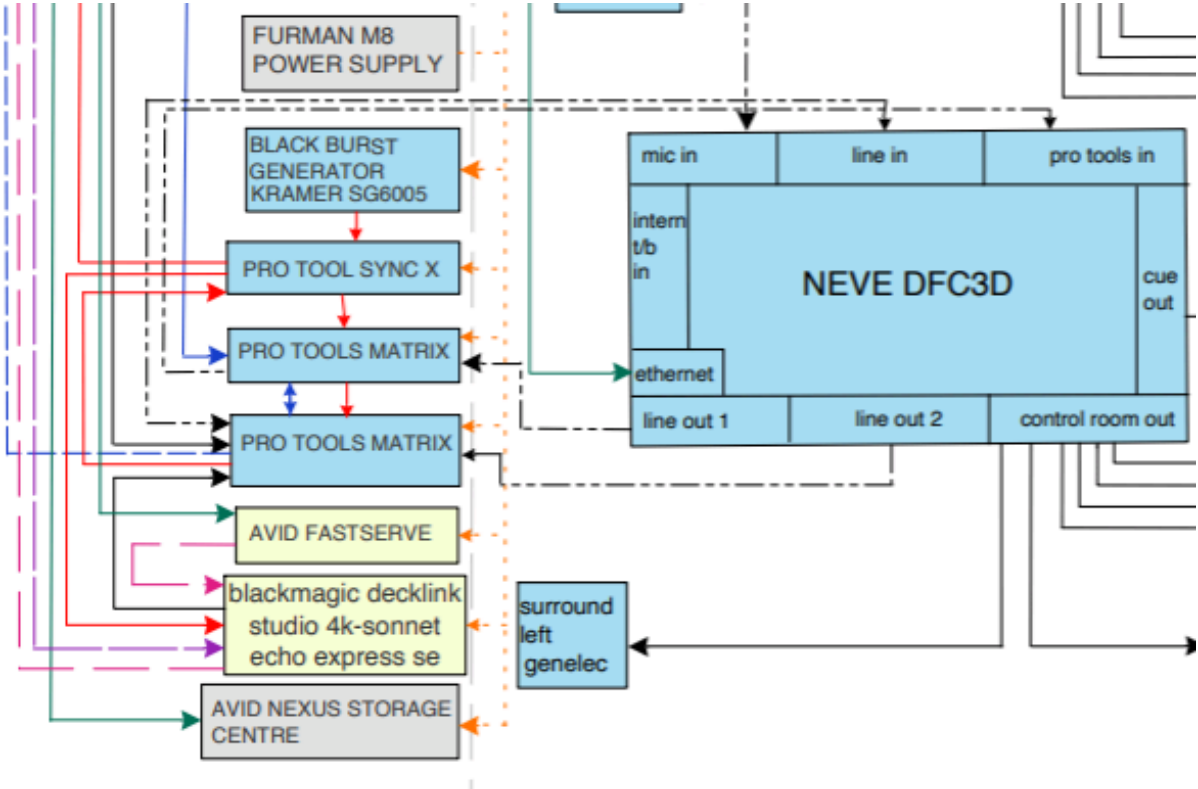

Image Credit: Bradley Mclaughlin (BDes Sound for Moving Image 2022)

Please note that this course specification is correct on the date of publication but may be subject to amendment prior to the start of the 2026-27 Academic Year.

Course Code	HECOS Code	Academic Session
USMIAVT302		2026-27

Course Title	Audio Visual Technology
Course Contact	Ronan Breslin

Credits	20
SCQF Level	9
When Taught	Stage 3, Semester 2

Associated Programmes	BDes Sound for Moving Image
Lead School	School of Innovation and Technology (SIT)
Other Schools	N/A
Date of Approval	Programme Approval February 2024

Course Introduction

This course explores knowledge and technical understanding of audio-visual (AV) systems and concepts. Audio Visual Technology equips students with the skills, knowledge and evaluative processes to design and troubleshoot audio visual systems, such as:

- A production Sound Cart to capture audio on a film set
- A studio for broadcasting a live music performance across radio
- A multi-channel audio visual installation for an art gallery
- A 5.1 dubbing studio for post-production workflows

Scientific and technical concepts will be introduced in an accessible manner to support its practical application throughout the students' education and future career. The project will be completed as a group to align with the industry standard of working in a team, mirroring professional practice.

Course Aims

The course aims to:

- Consolidate and expand upon students' technical knowledge of audio-visual systems
- Develop understanding of complex technical concepts underpinning digital film, video and interactive workflows, allowing students to evaluate audio-visual and interactive systems
- Equip students with the specialised knowledge and practical abilities to produce audio-visual-materials to industry defined technical standards, developing their creative practice within a professional context
- Help students develop confidence in creative communication of technical information and ideas in pragmatic and inclusive forms
- Support student collaboration in the application of professional audio-visual system design practices

Course Intended Learning Outcomes

By the end of this course students will be able to:

- . Develop and justify a schematic diagram for an audio-visual system within the context of professional practice and technical industry standards.
- Evaluate audio-visual systems using core principles of analogue and digital systems

- Apply informed problem-solving skills to analyse and remedy defects within audio-visual systems and material
- Collaborate with peers for the development of an audio-visual systems diagram
- Present technical information in a structured and accessible manner

Indicative Content

Much of the course will be lecture and workshop based. Students will engage with a range of key texts, papers and AV methodologies that will provide them with a fully integrated technical framework for studio-based learning. Students will also undertake practice-based projects that require the application of technical knowledge and problem-solving skills. Key content includes:

- The function of the ear and human auditory perception (head related transfer function, interaural time differences etc)
- Technical critical listening
- Introduction to acoustics
- Audio-Visual system diagrams and schematics
- Introduction to audio electronics
- Technical standards and measurements (such as “Loudness”)
- Fault-finding
- Digital audio-visual systems

Description of Learning and Teaching Methods

Once a week, students attend lectures that gradually build in complexity, followed by an interactive practical lab session, to demystify audio visual technologies, in a scaffolded hands-on approach. This will build students’ confidence to understand the connections and relationships between hardware components and learn of the most up-to-date software and export formats used across the creative industries.

Indicative Contact Hours

20

Notional Learning Hours

200

Description of Formative Assessment and Feedback Methods

Students will present their practical project to the class and tutor as a peer review presentation near completion of the project, with written and verbal feedback provided in real time, to recommend ways to strengthen the project.

Verbal feedback is also given at design and practical tutorials earlier in the course.

Practice class tests can be completed using quizzes/forms on Canvas.

Description of Summative Assessment arrangements

In this course, summative assessment simulates the professional design and sourcing process essential to the development and maintenance of industry standard audio-visual hardware configurations.

This Course has two summative assessment components:

Practical Project (Group)

This component is completed as a group resulting in a single group grade. This assessment component will demonstrate the student’s ability to identify the most appropriate electronic components, hardware, software and cabling arrangements for an audio-visual system of their

choosing (through the creation of a diagram and a written report). The written report allows them to evaluate and justify their choices in accordance with industry standards.

Multiple choice test

This component is completed individually (resulting in an individual grade for each student), and evaluates the student’s knowledge, understanding and problem-solving in the field of acoustic science and electronics through a multiple-choice test.

Students are awarded an aggregate grade based on the weighted grade of the two components. Submissions will be assessed and moderated in line with the Code of Assessment. Reassessment opportunities where a student has not passed the course are outlined in the Code of Assessment.

Description of Summative Assessment Method	Weight %	Submission week
Practical Project (Group) comprised by: <ul style="list-style-type: none"> - an audio-visual system diagram image for a chosen professional context with labelling of chosen hardware, connectors and software; - 1000 words written report justifying design choices 	80 %	Week 11
Test (individual): Multiple choice test to evaluate knowledge of key theoretical concepts (Individual)	20 %	Week 11

Exchange/Study Abroad	
Can this course be taken by Exchange/Study Abroad students?	Yes
Are all the students on the course taught wholly by distance learning?	No
Does this course represent a work placement or a year of study abroad?	No
Is this course collaborative with any other institutions?	No
If yes, then please provide the names of the other teaching institutions	

Reading and On-line Resources
The course indicative Reading and on-line resource list is accessible via Resource Lists in section “Audio Visual Technology” This list will be reviewed and updated annually to reflect course content and subject developments.